

SMPTE REGISTERED DISCLOSURE DOCUMENT

TICO Lightweight Codec Used in IP Networked or in SDI Infrastructures



Page 1 of 53 pages

The attached document is a Registered Disclosure Document prepared by the sponsor identified below. It has been examined by the appropriate SMPTE Technology Committee and is believed to contain adequate information to satisfy the objectives defined in the Scope, and to be technically consistent.

This document is NOT a Standard, Recommended Practice or Engineering Guideline, and does NOT imply a finding or representation of the Society.

Errors in this document should be reported to the proponent identified below, with a copy to eng@smpte.org.

All other inquiries in respect of this document, including inquiries as to intellectual property requirements that may be attached to use of the disclosed technology, should be addressed to the proponent identified below.

Proponent contact information:

Jean-Baptiste Lorent
intoPIX SA
Rue Emile Francqui, 9
1435 Mont-Saint-Guibert
BELGIUM

Email: jb.lorent@intopix.com

Table of Contents	Page
Introduction	3
1 Scope.....	4
2 Normative References.....	4
3 TICO Compression.....	5
3.1 Notation	5
3.1.1 Mathematical Operators	5
3.1.2 Terms and Definitions.....	6
3.2 TICO Characteristics Overview	7
3.2.1 Lightweight, High Quality and Low Latency in Software and Hardware.....	7
3.2.2 Encoding / Decoding Block Diagram.....	7
3.3 Picture Structure	8
3.4 Bitstream Syntax	9
3.4.1 Overview	9
3.4.2 Picture Syntax.....	10
3.4.3 Slice Syntax	11
3.4.4 Precinct Syntax.....	12
3.5 Bitstream Semantics.....	13
3.5.1 Picture Header Semantics.....	13
3.5.2 Slice Semantics	16
3.5.3 Precinct Semantics	16
3.5.4 Precinct Header Semantics	16
3.6 Decoding Process	18
3.6.1 Decoding Summary	18
3.6.2 Precinct Decoding.....	20
4 TICO Bitstream Mapping	31
4.1 Video Essence Box	31
4.1.1 Introduction	31
4.1.2 Video Essence Box Syntax	31
4.1.3 Video Essence Box Semantics.....	32
4.2 TICO Mapping to Active Video Area of 3G-SDI	39
4.2.1 Overview	39
4.2.2 3G-SDI container	39
4.2.3 Active Area with new TICO transported data	40
4.2.4 TICO Mapped in SDI with SMPTE ST 2022-5/6/7	44
4.3 TICO Mapping to RTP	45
Annex A RAND IP Licensing	47
Annex B Complementary Pseudo Code (Informative)	48
B.1 Coded Packets Decoding Pseudo Code.....	48
B.2 Raw Data Packet Unpacking Pseudo Code	50
Annex C IANA Considerations (Informative).....	52
Annex D Bibliography (Informative).....	53

Introduction

TICO is a video compression scheme developed by intoPIX SA, which stands for Tiny Codec. TICO answers the need for a low latency and light weight visually lossless mezzanine compression to manage and carry UHDTV format across 3G-SDI and IP networks in production workflows. TICO can compress image data up to 10240 H x 10240 W x 12 bit per components.

This SMPTE RDD describes the TICO bitstream, the decoding process, the provisions for mapping bitstreams onto a single 3G-SDI link and the provisions for mapping bitstreams onto an IP network.

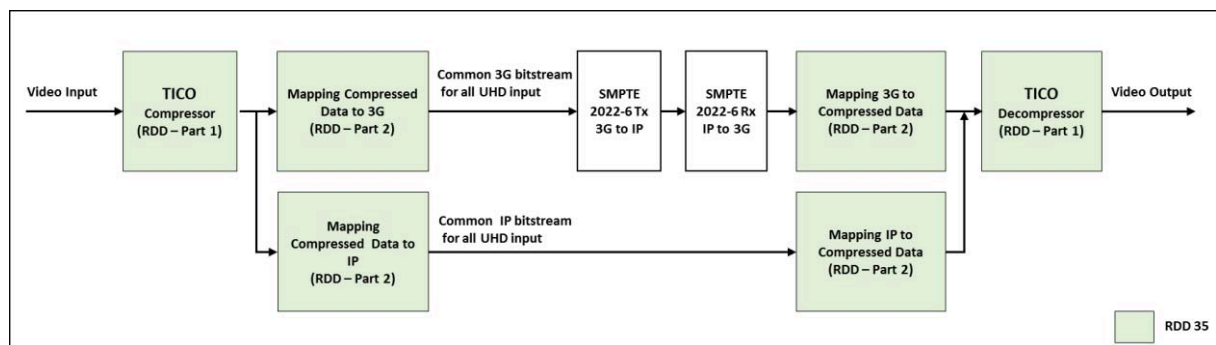

Figure 1 – TICO SMPTE RDD 35 scope

This SMPTE RDD contains sufficient information for knowledgeable individuals to build an implementation. An important feature of this mapping process is that it can be implemented in a practical form using currently available firmware and hardware. In the course of time, it could be implemented within new chip designs to ensure the minimum impact on hardware power requirements and physical size.

Note: "TICO" is trademark of intoPIX SA.

1 Scope

This Registered Disclosure Document (RDD):

- provides specification on TICO compression;
- specifies a TICO bitstream syntax containing information for interpreting the compressed image data;
- specifies TICO decoding processes for converting compressed image data to reconstructed image data based on TICO profile 2;
- specifies TICO bitstream mapping and detection in 3G-SDI environments (including protecting the EAV/SAV codes);
- specifies TICO bitstream mapping in IP networks with RTP mapping.

2 Normative References

Note: All references in this document to other SMPTE documents use the current numbering style (e.g. SMPTE ST 274:2008) although, during a transitional phase, the document as published (printed or PDF) may bear an older designation (such as SMPTE 274M-2008). Documents with the same root number (e.g. 274) and publication year (e.g. 2008) are functionally identical.

The following standards contain provisions which, through reference in this text, constitute provisions of this Registered Disclosure Document (RDD). At the time of publication, the editions indicated were valid. All standards are subject to revision, and parties to agreements based on this RDD are encouraged to investigate the possibility of applying the most recent editions of the standards listed below.

SMPTE ST 12-2:2014, Transmission of Time Code in the Ancillary Data Space

SMPTE ST 274:2008, Television — 1920 x 1080 Image Sample Structure, Digital Representation and Digital Timing Reference Sequences for Multiple Picture Rates

SMPTE ST 291-1:2011, Ancillary Data Packet and Space Formatting

SMPTE ST 292-1:2012, 1.5 Gb/s Signal/Data Serial Interface

SMPTE ST 299-1:2009, 24-Bit Digital Audio Format for SMPTE 292 Bit-Serial Interface

SMPTE ST 299-2:2010, Extension of the 24-Bit Digital Audio Format to 32 Channels for 3 Gb/s Bit-Serial Interfaces

SMPTE ST 352:2013, Payload Identification Codes for Serial Digital Interfaces

SMPTE ST 424:2012, 3 Gb/s Signal/Data Serial Interface

SMPTE ST 425-1:2014, Source Image Format and Ancillary Data Mapping for the 3 Gb/s Serial Interface

SMPTE ST 425-3:2015, Image Format and Ancillary Data Mapping for the Dual Link 3 Gb/s Serial Interface

SMPTE ST 425-5:2015, Image Format and Ancillary Data Mapping for the Quad Link 3 Gb/s Serial Interface

SMPTE ST 2022-6:2012, Transport of High Bit Rate Media Signals Over IP Networks (HBRMT)

SMPTE ST 2059-1:2015, Generation and Alignment of Interface Signals to the SMPTE Epoch

SMPTE ST 2081-10:2015, 2160-Line and 1080-Line Source Image and Ancillary Data Mapping for Single Link 6G-SDI

SMPTE ST 2082-10:2015, 2160-Line Source Image and Ancillary Data Mapping for 12G-SDI

SMPTE ST 2084:2014, High Dynamic Range Electro-Optical Transfer Function of Mastering Reference Displays.

Recommendation ITU-R BT.601-7 (03/2011), Studio Encoding Parameters of Digital Television for Standard 4:3 and Wide-Screen 16:9 Aspect Ratios.

Recommendation ITU-R BT.709-6 (06/2015), Parameter Values for the HDTV Standards for Production and International Programme Exchange.

Recommendation ITU-R BT.2020-2 (10/2015), Parameter Values for Ultra-High Definition Television Systems for Production and International Programme Exchange.

3 TICO Compression

3.1 Notation

3.1.1 Mathematical Operators

3.1.1.1 Arithmetic Operators

+	Addition
–	Subtraction (as a binary operator) or negation (as a unary prefix operator)
*	Multiplication
÷	Division (used in mathematical equations where no truncation or rounding is intended)
/	Integer division with truncation of the result toward negative infinity: $x / y = \text{floor}(x \div y)$
$n \bmod m$	Modulo operator with modulus m . Defined only for integers n and m with $m > 0$. Result is remainder r after integer division of n by m , $r = n - \text{floor}(n \div m) * m$; $0 \leq r \leq m - 1$.
<<	Left shift
>>	Right shift
=	Assignment
++	Increment by one
<	Smaller than
≤	Equal to or smaller than
==	Equal to
$\lceil x \rceil$	Ceiling operator
$\lfloor x \rfloor$	Floor operator

3.1.1.2 Mathematical Functions

Ceil(x)	Ceiling of x. Returns the smallest integer that is greater than or equal to x, x being a real number greater or equal than 0.
Floor(x)	Floor of x. Returns the highest integer that is less or equal to x, x being a real number greater or equal than 0.
Log2(x)	Logarithm of x to the base 2
Clamp(x,low,up)	Produces x when x in interval [low,up] else produces low (if x<low) or up (if x>up).
Max(x)	Maximum of x. Returns the maximum value

3.1.2 Terms and Definitions

3.1.2.1 Bitstream

Compressed image data using TICO compression. (For details, see section 3.3 Picture Structure).

3.1.2.2 Bit-plane

A one dimensional array of bits. A bit-plane refers to all the bits of the same position in a group of 4 consecutive binary-coded coefficients with a sign magnitude representation.

3.1.2.3 Coefficient

The values that are result of a wavelet transformation.

3.1.2.4 Component (comp)

A two-dimensional array of samples having the same designation in the output or display device. An image typically consists of several components, e.g. red, green and blue.

3.1.2.5 Decomposition level

A collection of wavelet sub-bands where each coefficient has the same spatial impact or span with respect to the source component samples.

3.1.2.6 Greatest Coded Line Index (GCLI)

Index of the most significant non-null bit-plane

3.1.2.7 Greatest Trimmed Line Index (GTLI)

Number of trimmed bits for a sub-band at a certain iteration

3.1.2.8 Picture

A segment of bitstream for one frame or field.

3.1.2.9 Precinct

A 2-pixel lines region of a transformed component, used as compression unit for limiting the size of packets.

3.1.2.10 Precision

Number of bits allocated to a particular sample, coefficient, or other binary numerical representation.

3.1.2.11 Quantization

A method of reducing the precision of the individual coefficients to reduce the number of bits used to entropy code them. This is equivalent to division while compressing and multiplication while decompressing. Quantization can be achieved by an explicit operation with a given quantization value.

3.1.2.12 Sign-magnitude

Binary representation of an integer value, starting with 1 sign bit (0 for positive integer, 1 for negative integer). The remaining bits in the number indicate the magnitude (or absolute value).

3.1.2.13 Sub-band (sb)

A group of transform coefficients from the same component resulting from the same sequence of low-pass and high-pass filtering operations, both vertically and horizontally.

3.2 TICO Characteristics Overview

3.2.1 Lightweight, High Quality and Low Latency in Software and Hardware

TICO algorithm offers simultaneously low complexity (in hardware and software), low latency and visually lossless quality at low compression ratio (typically 4:1).

- *Image quality :*

The compression scheme provides visually lossless compression and is robust to multiple encoding generations. The compression can be mathematically lossless at low compression rate due to the use of the 5/3 wavelet for lossless (reversible) transform.

The rate control mechanisms are guaranteeing an optimal quality within each precinct using contrast sensitivity function (CSF) for an optimal visual weighting and optimal transfer between precincts. TICO outputs at a constant bitrate (CBR) for an optimal quality.

- *Low latency:*

Due to its line-based wavelet transforms and entropy coding, a hardware implementation can achieve a latency of few lines of pixels for the encoding or decoding process. The latency is also fixed. With parallel processing, a software (CPU) implementation can achieve a single frame of latency for the encoding or decoding process.

- *Lightweight and low power in hardware:*

TICO should not require any external memory when implemented in a FPGA (& ASIC) since the codec needs only to buffer few lines of pixels. The structure of the algorithm, due to the use of light transforms, the entropy coding based on GCLIs, and the rate allocation does not require a large usage of logic. As a consequence, the codec does not consume a lot of power in a hardware circuit.

- *Lightweight and fast in software:*

TICO is highly parallelizable within pictures, slices and precincts which makes it very efficient and fast in CPU.

3.2.2 Encoding / Decoding Block Diagram

The encoder consists of an optional color transform (CT), a vertical discrete wavelet transform (DWT), a horizontal discrete wavelet transform, an integer converter and quantizer (Q), a light entropy (GCLI) coder and a packer with rate allocation.

It is illustrated in the Figure 2.