

5.4.4 Luminaires

The exposed conductive parts of luminaires shall be earthed.

Exception: Luminaires need not be earthed where—

- (a) *in accordance with Clause 5.4.1, earthing of equipment is not required; or*
- (b) *in accordance with Clause 5.4.3, a protective earthing conductor is not required; or*
- (c) *installed outdoors on a non-conductive pole and the luminaire is not in an earthed situation; or*
- (d) *supplied at ELV in accordance with Clause 7.5.*

5.4.5 Conductive supports for aerial conductors

Conductive poles, posts, struts, brackets, stay wires and other conductive supports for low voltage aerial conductors shall be earthed.

Exceptions:

- 1 *Conductive supports effectively and permanently separated from all conductors by double insulation need not be earthed. An acceptable method would include use of XLPE type X-90UV cable to AS/NZS 3560 with insulated strain clamps and double insulated connectors to AS/NZS 4396.*
- 2 *Conductive supports effectively and permanently separated from aerial conductors by insulators mounted on timber, or other insulating supports, need not be earthed where the space between the conductors and the conductive supports is not less than—*
 - (a) *for single-core conductors, half the space between the conductors as specified in Clause 3.12.5.4; or*
 - (b) *for multi-core conductors, 100 mm.*
- 3 *Conductive supports beyond arm's reach and effectively and permanently separated from any conductive guttering, roof or structural metalwork by a clearance or creepage distance of at least 25 mm need not be earthed.*
- 4 *Any stay wire that is attached to a conductive support fitted with a robust strain insulator so that any portion of the stay wire that is within arm's reach and that is readily accessible, is isolated from the remainder of the stay wire, need not be earthed.*

5.4.6 Structural metalwork including conductive building materials

5.4.6.1 General

Parts of structural metalwork, including conductive building materials, shall be earthed where—

- (a) the risk of contact with live parts of electrical equipment or insulated, unsheathed cables exists; or
- (b) double insulation of cables in contact with structural metalwork is not permanently and effectively maintained.

The breaking of a conductor at a termination shall not result in contact between unearthed conductive building material and—

- (i) live parts; or
- (ii) parts separated from live parts by single insulation.

This requirement may be satisfied by—

- (A) restraining the conductor by tying, lacing or clipping; or
- (B) containing the termination within a non-conductive shroud or enclosure.

5.4.6.2 Domestic electrical installations

Structural metalwork forming the frame of a dwelling shall be earthed.

5.4.6.3 Connection to protective earthing conductors

Earthing of parts of structural metalwork, including conductive building materials, may be effected by the connection of a protective earthing conductor of appropriate size at one point of the metalwork provided that the resistance between the earth bar and any part required to be earthed does not exceed 0.5 Ω .

5.4.7 Submersible pumps

The exposed conductive parts of a submersible pump shall be earthed by means of a protective earthing conductor that is terminated at the pump motor.

The termination shall be made in a manner that provides suitable sealing against ingress of moisture, protection against possible mechanical damage and corrosion likely to occur at the point of installation.

This requirement may be satisfied by terminating the protective earthing conductor on the motor at—

- (a) a terminal incorporated in a housing; or
- (b) an internal or external constructional component, in accordance with Clause 5.5.6.2.

5.4.8 Variable frequency devices

Devices that produce high frequency currents in the protective earth may produce touch voltages that are dangerous to persons and livestock.

NOTES:

- 1 The touch voltages may be as much as a 100 V but the manufacturer's advice should be sought when installing this type of device. These high frequency voltages may not be detectable using normal 50 Hz test instruments. An oscilloscope and ballast resistor should be used.
- 2 Attention is drawn to the safety requirements for electronic equipment in AS 62103.

A2

5.5 EARTHING ARRANGEMENTS

5.5.1 Main earthing conductor

5.5.1.1 Arrangement

An earthing conductor, deemed to be the main earthing conductor, shall be taken from the main earthing terminal/connection or bar at the main switchboard to an earth electrode complying with Clause 5.3.6.

The main earthing conductor shall be run in as direct a manner as possible and shall not be directly connected to the terminal of any accessory, luminaire or appliance.

Exceptions:

- 1 *The main earthing conductor may be taken to an earth bar or link within a customer's substation forming part of the electrical installation.*
- 2 *The main earthing conductor may be taken to an earthing conductor or terminal, provided by the distributor or, if required by the distributor, to a distributor neutral bar or link within the electrical installation.*

NOTE: An earthing conductor or terminal provided by the distributor may include a special earthing conductor, the conductive sheath of a supply cable, or a neutral bar or link at a substation.

5.5.1.2 Connection to earth electrode

The connection of the main earthing conductor to the earth electrode shall—

- (a) be accessible for visual inspection and for the purposes of testing; and
NOTES:
 - 1 Where necessary, access by means of an underground pit with its cover accessible above ground is considered acceptable, provided adequate space is available for the connection of test leads and the pit is suitably identified as to its purpose.
 - 2 Where the reinforcing steel is used as the earth electrode, this testing condition is deemed to be satisfied by the provision of a test point on the main earthing electrode.
- (b) be made by means of a suitable device in accordance with the manufacturer's specification that provides adequate electrical conductivity; and
- (c) provide protection against mechanical damage likely to occur to the main earthing conductor or the connection to the electrode at the location, in accordance with Clause 5.5.5.2; and
- (d) be suitably protected against corrosion in accordance with Clause 5.5.5.3.

NOTE: For location of earth electrodes, see Clause 5.3.6.4.

5.5.1.3 Labelling

The main earthing conductor shall have a permanent label attached at the connection to the earth electrode with a legible warning against disconnection in the following form:

WARNING: 'MAIN ELECTRICAL EARTHING CONDUCTOR—DO NOT DISCONNECT'

Exception: Where the method of connection to the electrode precludes disconnection this requirement need not apply.

5.5.1.4 Resistance

The resistance of the main earthing conductor, measured between the main earthing terminal/connection or bar and the earth electrode, including the connection to the earth electrode, shall be not more than 0.5 Ω .

5.5.2 Protective earthing conductors

5.5.2.1 Arrangement

All submain and subcircuit protective earthing conductors shall be directly connected to the main earthing conductor or to another point on an earthing system that is connected to the main earthing conductor.

The connection shall be made at one or a combination of the following points:

- (a) An earthing terminal/connection or bar at the main switchboard provided specifically for the connection of earthing conductors and that is directly connected to the main earthing conductor.
- (b) Any point on the main earthing conductor.
- (c) An earthing terminal/connection or bar at a distribution board provided specifically for the connection of protective earthing conductors and arranged to comply with Clause 5.5.2.2.
- (d) Any point on a protective earthing conductor providing facilities for earthing at a distribution board and arranged to comply with Clause 5.5.2.2.

NOTES:

- 1 Examples of earthing connections are shown in Figure 5.3.
- 2 Refer to Clause 5.5.3.1 where the earthing system in an outbuilding is to be treated as a separate MEN installation.

5.5.2.2 Restricted connections

5.5.2.2.1 Circuits

The protective earthing conductor for a circuit that is incorporated in the same cable sheath or wiring enclosure as the associated live conductors for the circuit shall only be used for the earthing of equipment supplied from the circuit.

Exception: This does not preclude an unenclosed common protective earthing conductor being used for a number of different circuits.

5.5.2.2.2 *Earthing of equipment*

A protective earthing conductor that originates at a distribution board, in accordance with Clause 5.5.2.1 (c) or (d), shall not be used for the earthing of electrical equipment that is supplied from another switchboard.

5.5.2.2.3 *Earthing facilities for distribution boards*

A protective earthing conductor that originates at a distribution board, in accordance with Clause 5.5.2.1 (c) or (d), shall not be used for the provision of earthing facilities for another distribution board.

Exceptions:

- 1 *This requirement need not apply where earthing facilities for a distribution board originate from the same distribution board as the associated active conductors supplying the distribution board.*
- 2 *A common protective earthing conductor connected to the main earthing conductor in accordance with Clause 5.5.2.1 (a) or (b) may be arranged to provide earthing facilities at a number of distribution boards provided that—*
 - (a) *the continuity of the protective earthing conductor shall not be dependent on a terminal at a distribution board; and*
 - (b) *a direct connection shall be made between the common protective earthing conductor and any branch protective earthing conductor to a distribution board.*

A1

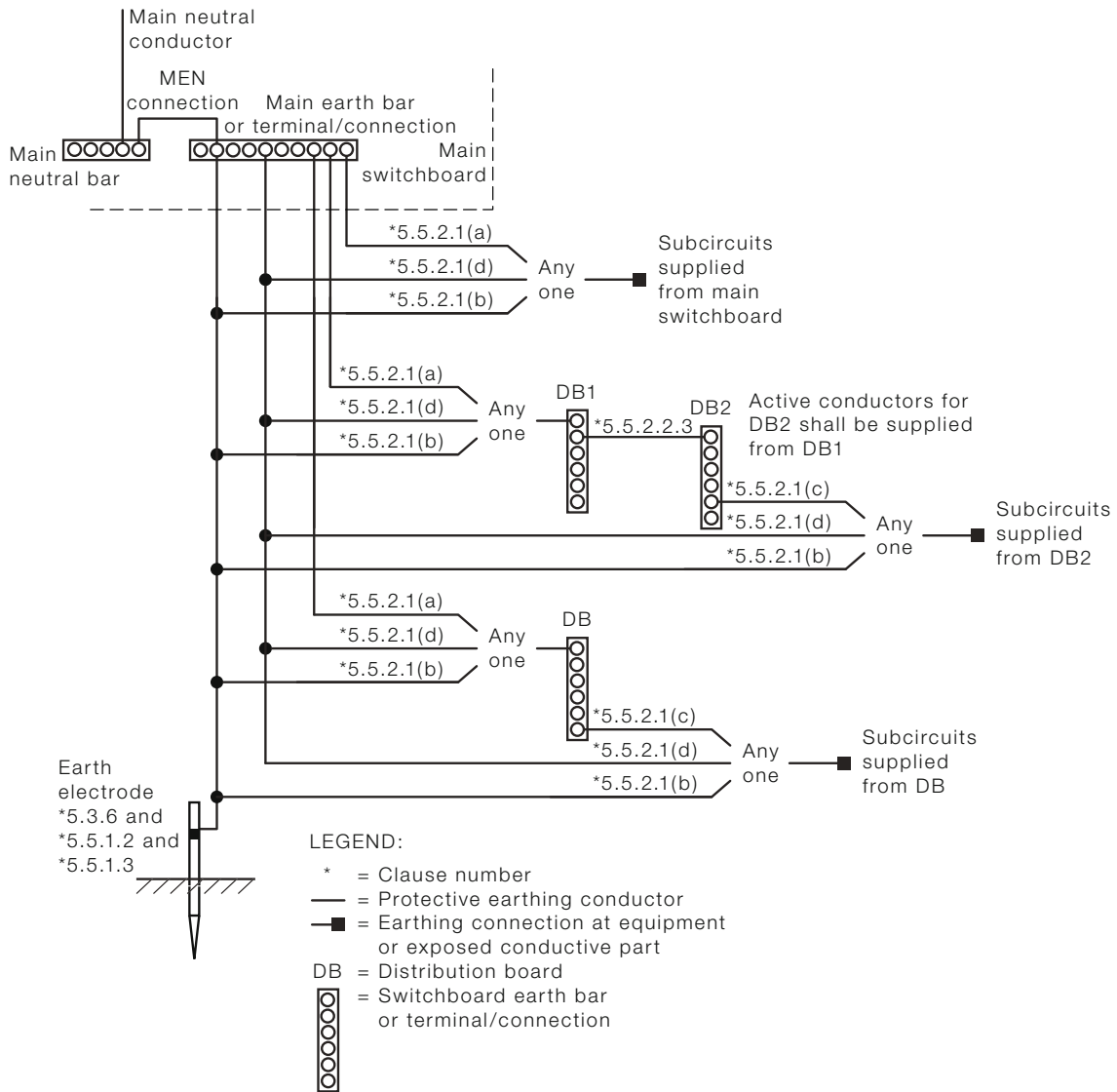

FIGURE 5.3 EXAMPLES OF EARTHING ARRANGEMENTS (CLAUSES 5.5.2.1 AND 5.5.2.2.3)

5.5.3 Particular methods of earthing

5.5.3.1 Outbuildings

All parts of an electrical installation in or on an outbuilding that are required to be earthed in accordance with Clause 5.4 shall be earthed by one of the following methods:

- (a) *Connection to the electrical installation earthing system* The earthing system in the outbuilding shall be connected to a protective earthing conductor connected in accordance with Clause 5.5.2.1.

- (b) *Separate MEN installation* The earthing system in the outbuilding shall be connected to the submain neutral conductor supplying the outbuilding. In this case the submain neutral conductor supplying the outbuilding is a combined protective earthing and neutral (PEN) conductor.

The electrical installation in the outbuilding shall be regarded as a separate electrical installation, and shall be earthed in accordance with other relevant Clauses of this Standard and with the following requirements:

- (i) There shall be not more than one MEN connection in any one outbuilding.
- (ii) The distribution board in the outbuilding shall be regarded as a main switchboard for the purpose of effecting the MEN connection.
- (iii) The earthing conductor between the distribution board in the outbuilding and the earth electrode shall be regarded as a main earthing conductor for the purposes of earthing of the electrical installation in the outbuilding.
- (iv) The submain supplying the outbuilding shall be run either—
 - (A) directly from the main switchboard; or
 - (B) from the main switchboard via distribution boards in one or more other outbuildings, to one distribution board only in the outbuilding.
- (v) Where the combined protective earthing and neutral (PEN) conductor supplying the distribution board in the outbuilding runs from the main switchboard via distribution boards in one or more other outbuildings, the terminals on such distribution boards shall not be depended on for continuity of the combined protective earthing and neutral (PEN) conductor.
- (vi) The combined protective earthing and neutral (PEN) conductor supplying the distribution board in the outbuilding should not be connected in parallel, by means of earthing or equipotential bonding conductors, with conductive pipes or structural metal within the electrical installation.

NOTE: Particular care is required where conductive pipes and such items as telecommunication cable sheaths, covered walkways, etc may be continuous between separate buildings and thus establish a parallel earth/neutral path.

5.5.3.2 *Wiring systems*

- (a) *Conductive wiring enclosures* Exposed conductive parts of wiring enclosures shall be earthed at the end adjacent to the switchboard or accessory at which the wiring enclosure originates.
- (b) *Conductive sheaths, armours and screens of cables or cords* The conductive sheathing, armouring or screening of cables or cords required to be earthed shall be earthed at the end adjacent to the switchboard or accessory at which the cable or cord originates.

Exceptions:

- 1 *A conductive screen or braid embodied in a cable or flexible cord need not be earthed where—*
 - (a) *it is separated from the live conductors by double insulation; and*
 - (b) *sheathed or covered overall with non-conductive material; and*
 - (c) *all joints to and terminations of the screen or braid are suitably separated from exposed conductive and live parts.*
- 2 *A conductive cable sheathing, armouring, screening or braiding need not be earthed where, in accordance with Clause 5.4.1, earthing is not required.*

5.5.3.3 *Earthing of electrical equipment supplied by flexible cord or flexible cable*

The exposed conductive parts of electrical equipment supplied by flexible cord or flexible cable shall be earthed by connection to a protective earthing conductor incorporated with the associated live conductors in the sheath, braid or enclosure of the supply cord or cable.

5.5.3.4 *Switchboards*

Electrical equipment mounted on the conductive framework of a switchboard may be earthed in accordance with Clause 5.3.2.3 (c).

5.5.3.5 *Unprotected consumers mains*

Exposed conductive parts associated with consumers mains not provided with short-circuit protection on the supply side shall be earthed by a conductor with a current-carrying capacity not less than that of the main neutral conductor.

This conductor shall be connected to—

- (a) the main neutral conductor or bar; or
- (b) the main earthing terminal/connection or bar, in which case, in accordance with Clause 5.3.5.2, the cross-sectional area of the MEN connection shall be not less than that of the main neutral conductor.

NOTES:

- 1 *Where double insulation of the consumers mains conductors is maintained up to the supply terminal/s of the service protective device/s, and short-circuit protection is provided by that device, this requirement need not apply.*
- 2 *A system that is deemed to provide double insulation for aerial conductors would include use of XLPE type X-90UV cable to AS/NZS 3560 with insulated strain clamps and double insulated connectors to AS/NZS 4396.*
- 3 Exposed conductive parts associated with consumers mains include—
 - (a) switchboard cases, surrounds and enclosures; and
 - (b) wiring enclosures; and
 - (c) boxes and accessories; and
 - (d) supports for aerial conductors

- 4 A distributor's upstream service protective device may provide short-circuit protection of consumers mains.

5.5.4 Continuity

5.5.4.1 General

Earthing conductors shall be suitably protected against mechanical and chemical deterioration and electrodynamic forces. Star or cutting washers or similar devices that effectively cut through paint or similar coatings are considered to be an acceptable method of ensuring earth continuity across bolted or clamped joints between metal equipment panels or framework that have painted or coated surfaces.

5.5.4.2 Conductive wiring enclosures

Conductive wiring enclosures and associated fittings that require to be earthed, including those used as an earthing medium, shall be mechanically and electrically continuous. The impedance of such a wiring enclosure earthing arrangement shall be in accordance with Clause 5.7.

5.5.4.3 Conductive sheaths, armours and screens of cables

Conductive sheaths, armours and screens of cables and associated fittings that require to be earthed, including those used as an earthing medium, shall be mechanically and electrically continuous. The impedance of such cable components and associated fittings providing earth continuity shall be in accordance with that required for a copper earthing conductor determined in accordance with Clause 5.3.3.

5.5.4.4 Connecting devices

Where electrical equipment is connected to the installation wiring by a connection in the form of a plug and socket-outlet, appliance plug or similar connecting device, any connection of exposed conductive parts to earth shall be—

- (a) made automatically, before the live connections are made, when any plug portion is inserted in the corresponding socket-outlet; and
- (b) broken automatically, not before the live connections are broken, when any plug portion is withdrawn from the corresponding socket-outlet.

5.5.5 Installation

5.5.5.1 General

All earthing conductors and other forms of earthing medium shall be installed in a manner that provides adequate protection against likely mechanical damage, inadvertent interference and chemical deterioration.

NOTE: In areas of high lightning activity, the provisions of AS/NZS 1768 should be considered.

5.5.5.2 Protection against mechanical damage

Earthing conductors shall be protected against becoming displaced, damaged or cut by means of one or a combination of the following methods appropriate to the expected conditions of mechanical damage at the point of installation:

- (a) Fixing by means of clamps, clips, saddles, clouts or similar devices that shall not pass between the strands of the conductor or damage the conductor.
- (b) Guarding by metallic barriers or other suitable robust material.
- (c) Installing in a wiring enclosure, in accordance with Clause 3.10.2.

5.5.5.3 *Protection against corrosion*

Earthing conductors, and any associated fixing devices, shall be protected from corrosion, including the effects of moisture or contact with dissimilar metals.

Earthing conductors and associated fittings and fixing devices shall comply with the following requirements:

- (a) *Underground and damp situations* All joints and terminations installed in an underground location or other damp situation shall be sealed to prevent the entry of moisture. All associated fittings and fixing devices in such locations shall be constructed of, or protected by, corrosion-resistant material.
- (b) *Exposed to the weather* All joints, terminations, fittings and fixtures in locations exposed to the weather shall be constructed of, or protected by, corrosion-resistant material in such a manner that will prevent the entry of moisture affecting the conductor.

5.5.5.4 *Aerial earthing conductors*

Aerial earthing conductors shall be—

- (a) supported in accordance with Clause 3.12.5; and
- (b) identified in accordance with Clause 3.8.3.4.

5.5.5.5 *Buried earthing conductors*

- (a) *Installation conditions:* A bare or insulated earthing conductor buried direct in the ground or installed in an underground enclosure shall be subject to the depth of laying and mechanical protection requirements appropriate to the method of installation for a sheathed conductor, in accordance with Clause 3.11.
- (b) *Bare earthing conductors* In addition, bare earthing conductors shall be buried direct in the ground or installed in an underground enclosure only where they are copper not less than 25 mm².
- (c) *Walls and partitions* An earthing conductor that passes through a wall or partition shall not be considered as a buried earthing conductor.

5.5.6 **Connections**

5.5.6.1 *Conductors*

Connections in earthing conductors shall comply with Clause 3.7.

5.5.6.2 *Constructional components*

The exposed conductive parts of electrical equipment may be earthed by the connection of a protective earthing conductor to a constructional bolt, stud, screw or similar terminal arrangement forming an integral part of the electrical equipment.

Such earthing shall be in accordance with the following requirements:

- (a) The terminal shall be mechanically and electrically continuous with the exposed conductive part to be earthed.
- (b) The protective earthing conductor shall be capable of being removed from the terminal without—
 - (i) reducing the effectiveness of the bolt, stud, or screw as a constructional medium in any way; or
 - (ii) causing any parts of the electrical equipment to lose their relative rigidity.

A stud that also serves for securing a terminal cover may be used provided that it complies with Items (c) and (d).

- (c) The removal of any covers or parts that are likely to be removed to—
 - (i) obtain access to terminals; or
 - (ii) adjust the electrical equipment or parts thereof;shall not disturb or reduce the effectiveness of the earthing connection.
- (d) The bolt, stud or screw shall not be used to—
 - (i) fix the electrical equipment in position; or
 - (ii) adjust the position of the electrical equipment or any part of it.

5.6 EQUIPOTENTIAL BONDING

5.6.1 General

Equipotential bonding is intended to minimize the risks associated with the occurrence of voltage differences between exposed conductive parts of electrical equipment and extraneous conductive parts.

NOTE: Such voltage differences can arise from a range of sources including, but not limited to—

- (a) a fault external to the installation, either on an incoming extraneous conductor (such as a water or gas pipe, etc.) or on the supply neutral and protective earthing system; and
- (b) distribution system load current in the soil passing through a swimming pool; and
- (c) telecommunication system voltages on equipment adjacent to exposed conductive parts; and
- (d) lightning discharges either directly within the installation or effecting the incoming extraneous conductor or the supply mains.